

ENGINEERING BULLETIN

January 1, 2002

New Drain Valve Fitting for Hastings FF1039 Fuel/Water Separator

Hastings Filters introduces a new hose-barb fitting for the self-venting drain valve on the FF1039 fuel/water separator. This fitting can be attached to the drain valve to accommodate the use of the OEM drain hose found on most applications using this filter. This method routes the drained water away from the engine, making it cleaner and easier to service.

To install the hose-barb fitting, insert the four prongs of the fitting into the four holes located in the star-wheel of the drain valve. Slide the rubber hose over the hose-barb. Once installed, the fitting will swivel to allow easy opening and closing of the drain valve.

This fitting will be included with the FF1039 fuel/water separator in early 2002. It will also soon be available for the FF1039-SP.

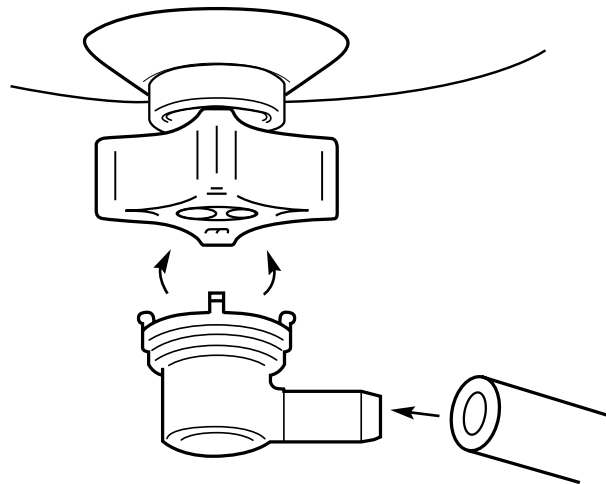

**If you have further questions,
please contact our
Service Engineering Team at (800) 887-8836.**